



Features

- On-Off-On Multi-Pole in one
 - Replace Toggle SW / Slide SW circuit
 - Replace SPDT SW
- Recode function :
8 positions = 3^8 with two common pin Connection circuit



DMXS

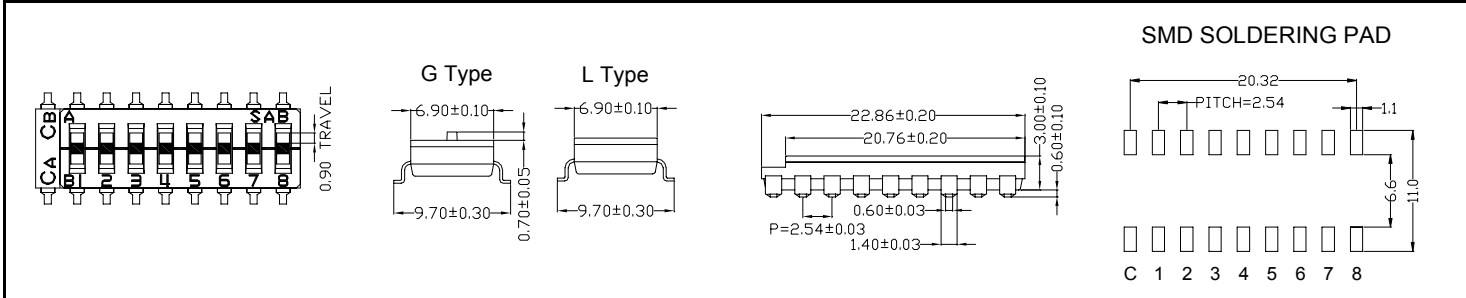

DMXA/H

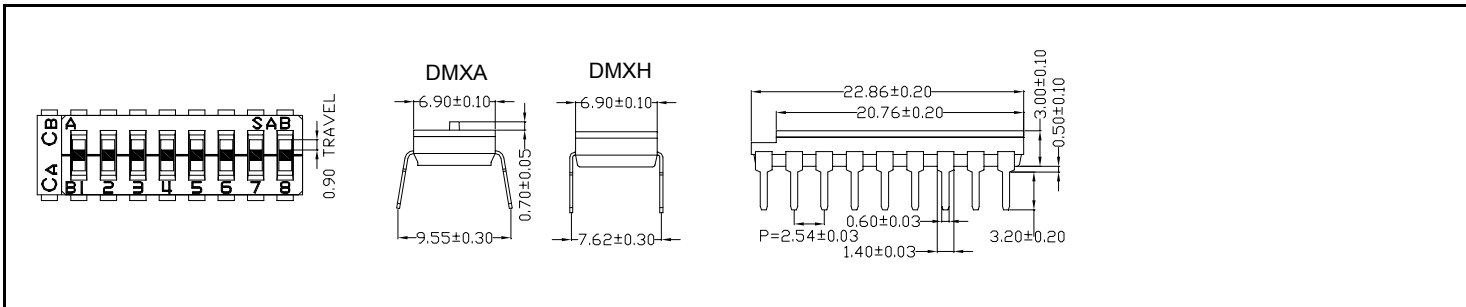

Specifications

- Contact Rating
- Switching 25mA, 24VDC
- Non-Switching..... 100mA, 50VDC
- Contact Resistance
- Initial 50mΩ Max.
- After Life Test 100mΩ Max.
- Insulation Resistance 100M min at 500VDC
- Dielectric Strength 500VDC /1 minute
- Operating Force..... 1,000g Max.
- Mechanical Life..... 3,000 cycles
- Electrical Life..... 2,000 cycles

Materials

- Cover & Base:** High Temperature UL 94V-0 Thermoplastic, Black.
- Actuator:** High Temperature UL 94V-0 Thermoplastic, White.
- Terminal & Movable Contact:** Copper Alloy with Gold Plated or Pure-Tin.
- Terminal:** Copper Alloy with Gold Plated or Pure-Tin.
- Tape Sealed:** Polyimide film.

Wiring Diagram

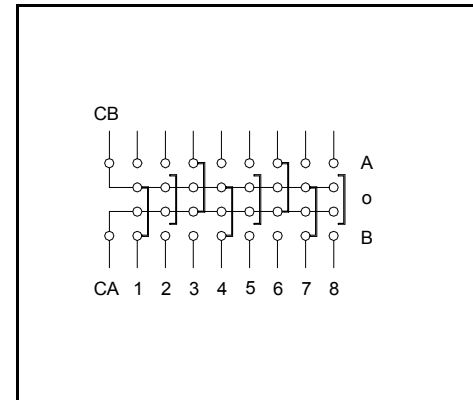

Soldering Information

- Hand Soldering
- Soldering Iron 30W or under at 350 / 3 sec Max or at 270 / 5 sec Max.
- Wave Soldering
- Temperature: 260 10 sec. Max.
- Reflow Soldering
- 260 ±5 within 30sec. In-line or Batch system.
- L & G Type: un-washable & un-accept reflow process.
- Keep all actuators in "OFF" position during soldering and cleaning process.

Packaging Information

- All DIP switches are shipped in Tube.
- DMXS can be packed by Tape & Reel.
- Actuators all in "OFF" position.

Ordering Information

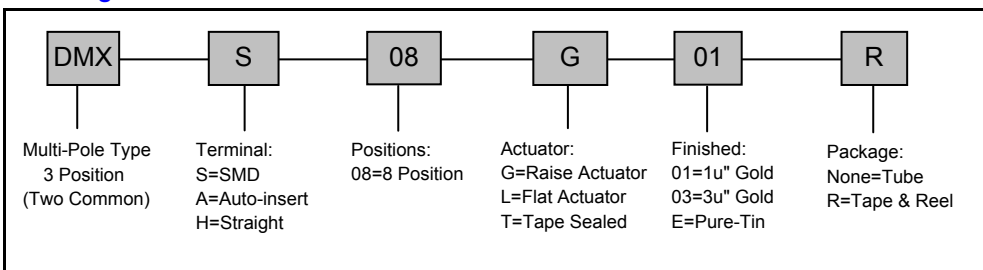

Package

P/N	No. Of Pole	Dim. A	Quantity per Tube
DMXS/A/H08	8	21.06mm	22